



BRÜEL & KJÆR

Number 1
Jan. 1949

Technical Review

Teletechnical, acoustical and medical research

New Instruments in Acoustic Research

by
Per V. Brüel, D. Sc.*)

Summary.

A new electrodynamic high-speed level recorder with writing speeds up to 1000 db/sec and a new beat-frequency oscillator with regulating compressor are described. It is shown how it is possible with these two instruments to make recordings of frequency responses of microphones, amplifiers, loudspeakers, etc., building-acoustic recordings of sound insulation of walls, and automatic recordings of reverberation curves in halls.

Since long it has been Brüel & Kjær's desire to develop a level recorder faster than any high-speed level recorders known before, as, for example, the well-known Neumann recorder. In co-operation with the Acoustics Laboratory at the Chalmers University of Technology at Gothenburg we therefore examined various principles for recorders, and presently it was decided to make an electrodynamic recorder.

The principle of the apparatus is shown in fig. 1. The writing arm and the movable switch on the input potentiometer are both connected to a coil which is movable in a magnetic field. The coil is without current when the input voltage on the amplifier is 10 mV.

Any deviation of the input voltage on the amplifier will produce a current in either one or the other direction in the coil. In this manner the coil is set in motion and with the potentiometer arm searches out a new position, in which the current in the coil ceases again.

Six different interchangeable potentiometers can be used on this recorder. Four of them are logarithmic and have the ranges: 10, 25, 50 and 75 db. All these potentiometers have logarithmic resistance distribution. A fifth potentiometer gives linear scale from 10 to 110 mV and has hyperbolic resistance distribution. The sixth is a phon potentiometer for recording of noise from 35 to 110 phons. Fig. 3 shows the inside and outside of the potentiometer.

Fig. 1 and 2 show the construction of the recorder. The magnetic circuit consists of two cylindrical permanent magnets producing a radial field. The coil is mounted upon two light brass tubes which run on two hard

*) Since January 1948 at Brüel & Kjær A/S, Nærum, Denmark. Before that time associate professor at the Acoustics Laboratory, Chalmers University of Technology, Gothenburg, Sweden.

stretched steel-wires.*) The writing arm with its sapphire draws across 50 mm waxed paper of a total width of 65 mm. The paper can by means of a motor and a gear-box be driven at 10 different speeds: 100 — 30 — 10 — 3 — 1 — 0.3 — 0.1 — 0.03 — 0.01 and 0.003 mm/sec. The potentiometer has 108 silver lamellae and the distance between two contacts is 0.5 mm. This corresponds to an accuracy of the instrument of $1/4$ db with the 50 db potentiometer.

In addition to the scratcher the recorder is provided with facilities for the mounting of an ink pen, thus making it practicable to draw curves on ordinary white recording paper. One ink-filling is enough for about 10 minutes' writing. A heavy objection to the waxed paper is that the recorded curves are too thin to reproduce, why it sometimes is a great advantage to draw ink curves, which furthermore may be drawn in several colours.

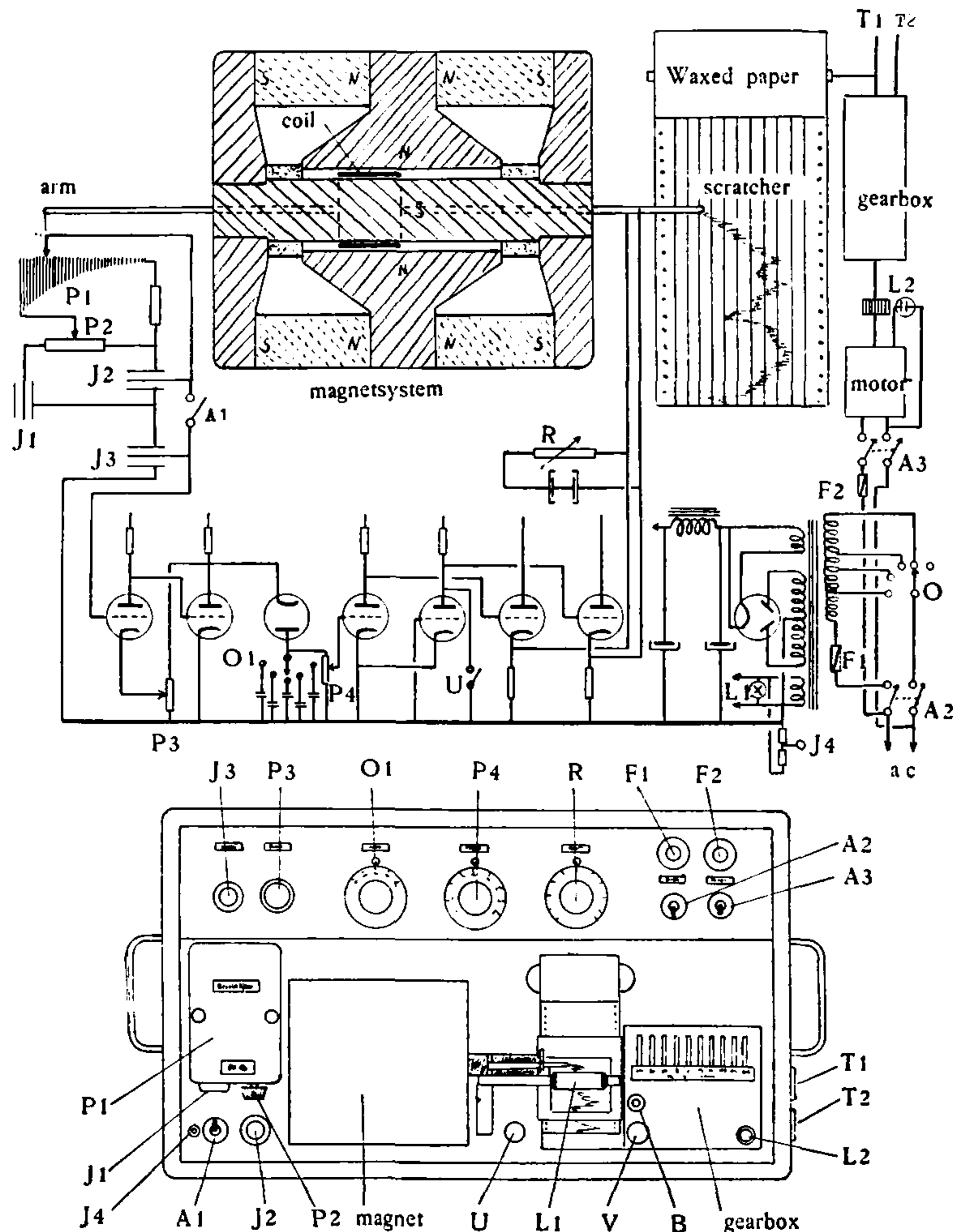

Fig. 1. Principle for the new electrodynamic recorder.

*) The mechanical development of the coil system was made by Mr. H. Nielsen.

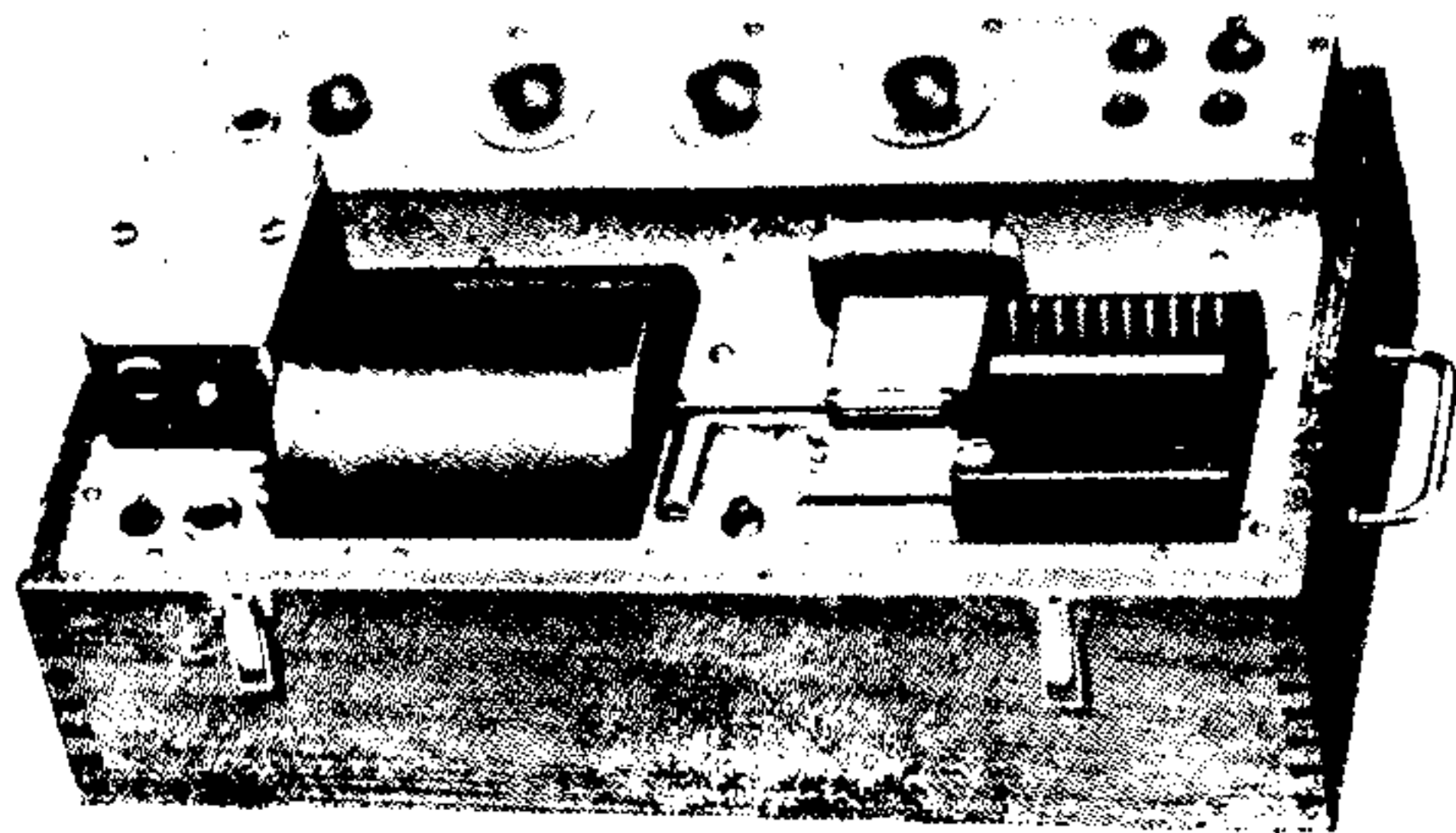

Fig. 2. Photograph of the electrodynamic recorder in its commercial form. Type 2301.

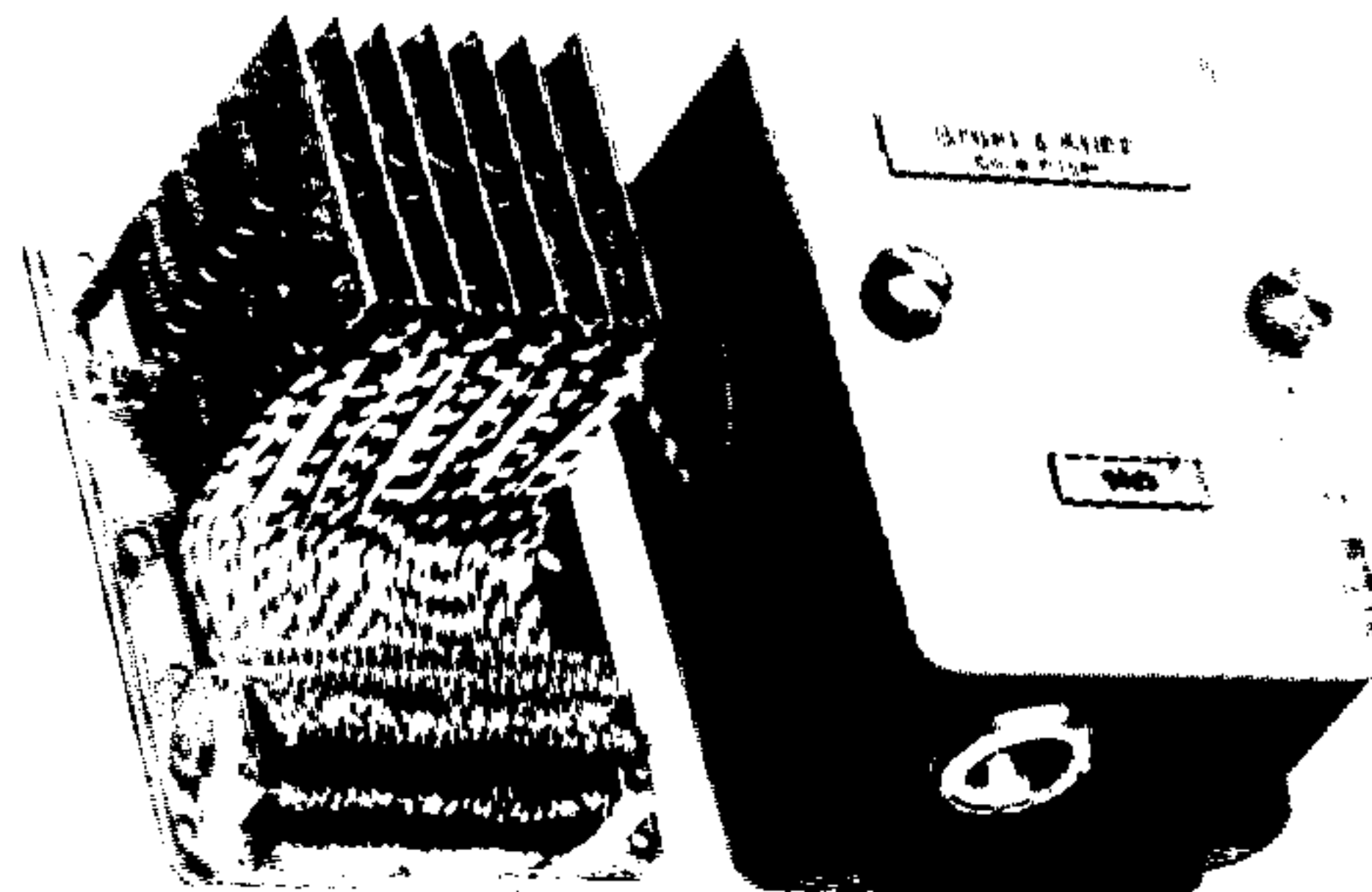

Fig. 3. View of the changeable potentiometers. Type 2301 a.

The electrical part of the recorder is built of amplifier, rectifier, a push-pull d. c. amplifier, and a balanced power stage. The rectifier contains a diode which gives regulating voltage to the tubes in the d. c. amplifier. The grid of the power tubes have equal voltages when the diode voltage corresponds to an input voltage of 10 mV on the amplifier. In this case the coil is without current. By altering the capacities in the rectifier circuit it is possible within certain limits to vary the time constants and also the lower limiting frequency. If the moving system was without friction, any recorder according to the potentiometer principle would be unstable, since, when a certain mass moves at a certain speed across the equilibrium position, the current will still remain in the coil for a moment until the electrical system has changed and driven the current in the opposite direction through the coil. The length of this moment is dependent on the time constants of the electrical circuit, mainly determined by the R.C.-network in the rectifier section.

As the rectifier shall have a comparatively low limiting frequency, the time constants should have a reasonable magnitude. This means that some energy necessarily must be fed into the moving system in the short interval between the passage through the equilibrium position and until the current in the coil has turned. This energy, the magnitude of which is directly dependent on the velocity of the moving system and the time constants of the electrical system has therefore to be eliminated by a damping, in this case obtained by a mechanical friction on account of the long coil tubes and furthermore increased by a variable shunt resistor placed across the coil. In order not to diminish the driving force, and thereby the accuracy of the coil position, when the system moves very slowly, a big capacitor is put in series with the shunt resistor, thus preventing any transmission of d. c. current.

The maximum speed of the recorder is found by varying the input voltage in steps and determining the slope of the recorded curve. This speed is in the present case mainly determined by the damping from the electrical system, by the magnitude of the driving power, and by the inertia in the mechanical system.

Fig. 4 A shows the recording of a rectangular curve. The maximum writing speed is indicated by the slope of the line and is determined from the pictured curves to be about 1000 db/sec. The curves are recorded with

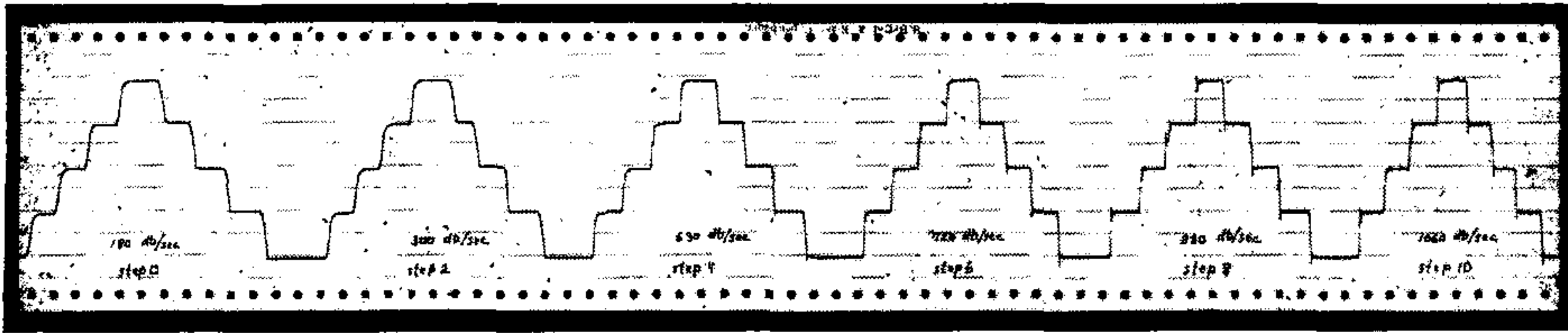

Fig 4 A.

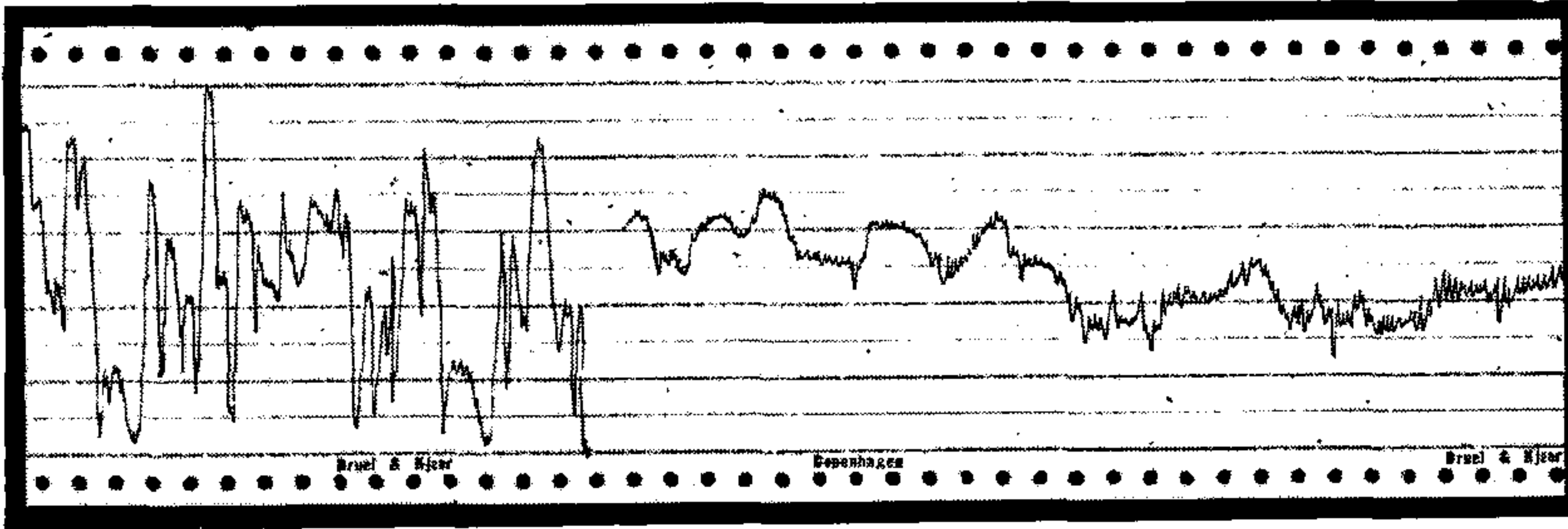

Fig. 4 B.

Fig. 4 C.

Fig. 4. Curves recorded with the level recorder. All curves are made by ink and are unretouched. A. Step curves made with variable recording speed from 150 to 1000 db/sec., paper speed 30 mm/sec. B. Level curves of speech made with a recording speed of 800 db/sec. C. Level curves of church music.

the 50 db potentiometer. The pressure impulses from normal speech and from music in a church are shown in fig. 4 B and C, respectively.

To the recorder is constructed a beat-frequency oscillator*), shown in fig. 5, with an outfit especially designed for acoustic purposes. Thus it has built-in frequency modulation with variable modulation frequency and modulation depth, and a special push button cuts off the output power entirely noiseless. Fig. 6 shows the block diagram of the whole oscillator. The noiseless switch cuts off one HF-oscillator. The frequency modulation is done by connecting a reactance tube, fed by a separate oscillator, to one of the HF-oscillators. Furthermore the beat-frequency oscillator is equipped with a compression unit, inserted between one of the HF-oscillators and the mixer, to control the voltage to the mixer, and thereby also the output of the entire oscillator.

The control voltage to the compressor can, for example, be delivered from an ordinary microphone via a microphone amplifier, and it is so arranged that the beat-frequency oscillator automatically will regulate the power to such a level that the sound pressure on the place of the microphone always will be constant. Naturally the beat-frequency oscillator can also be made to give constant voltage or constant current by controlling from a voltage- or current-sensitive unit, respectively. We have succeeded in getting the regulation speed of the compressor up to about 400 db/sec almost without any distortion on the low frequencies as far down as 40 c/s. The beat-frequency oscillator is supplied with a worm-drive, which with a flexible shaft can be connected with the level recorder. Thus the frequency scale will move synchronously with the paper on the recorder.

*) Designed by Mr. V. Kjær.

With these two instruments it is now practicable to make a series of full- and half-automatic acoustic measurements in an extremely convenient way. In fig. 7 the apparatus appears applied to the recording of the frequency response characteristic of a microphone, on which the beat-frequency oscillator maintains constant sound pressure, independent on the frequency. The recorder will then automatically draw the frequency response characteristic of the microphone. Beforehand, the recording paper is arranged with print, by means of which the frequency can be read directly on the paper; compare fig. 8 A. If no such printed paper is at hand, the ordinary recording pa-

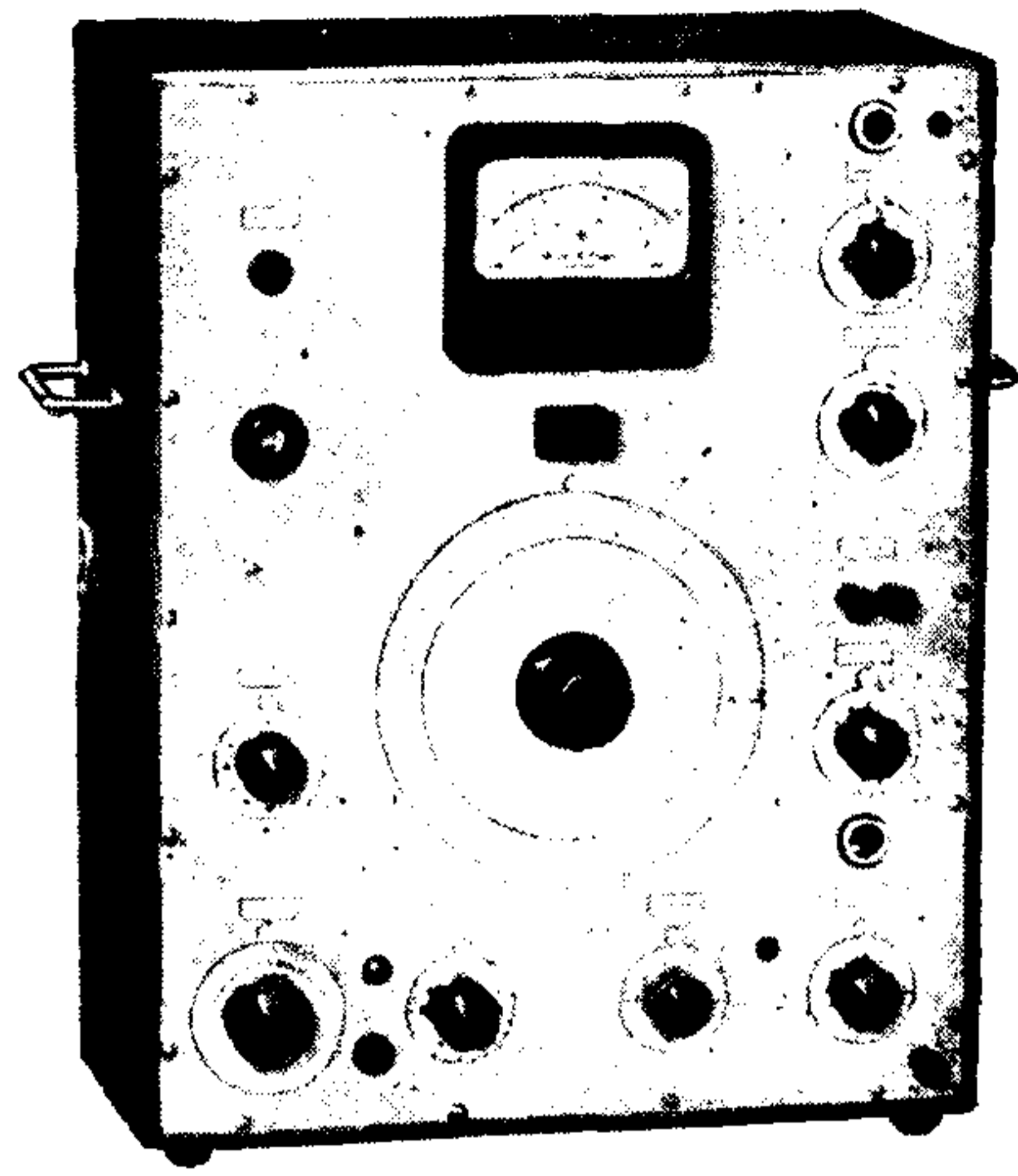

Fig. 5. Photograph of the new beat frequency oscillator with compressor in its commercial form.

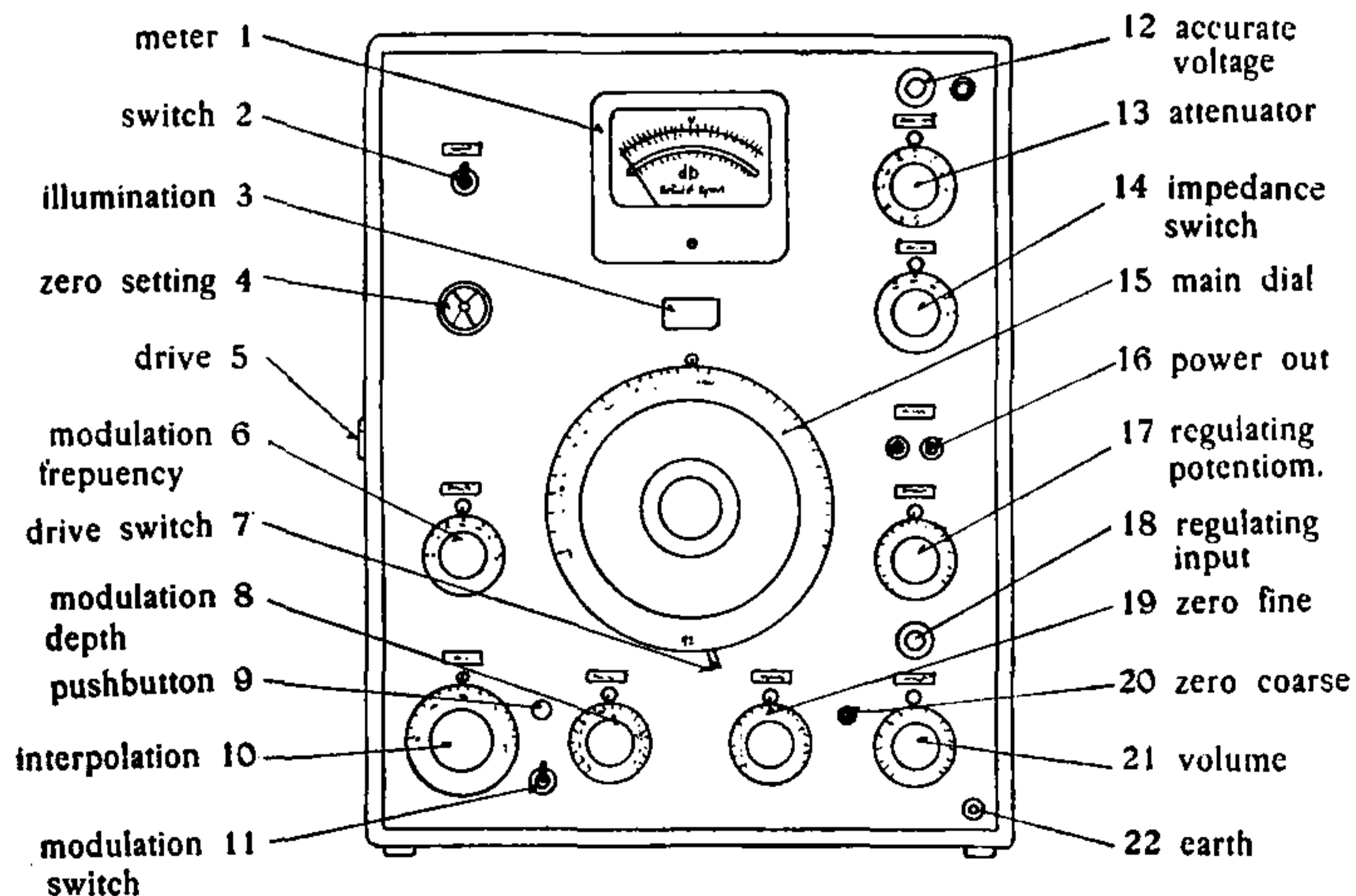
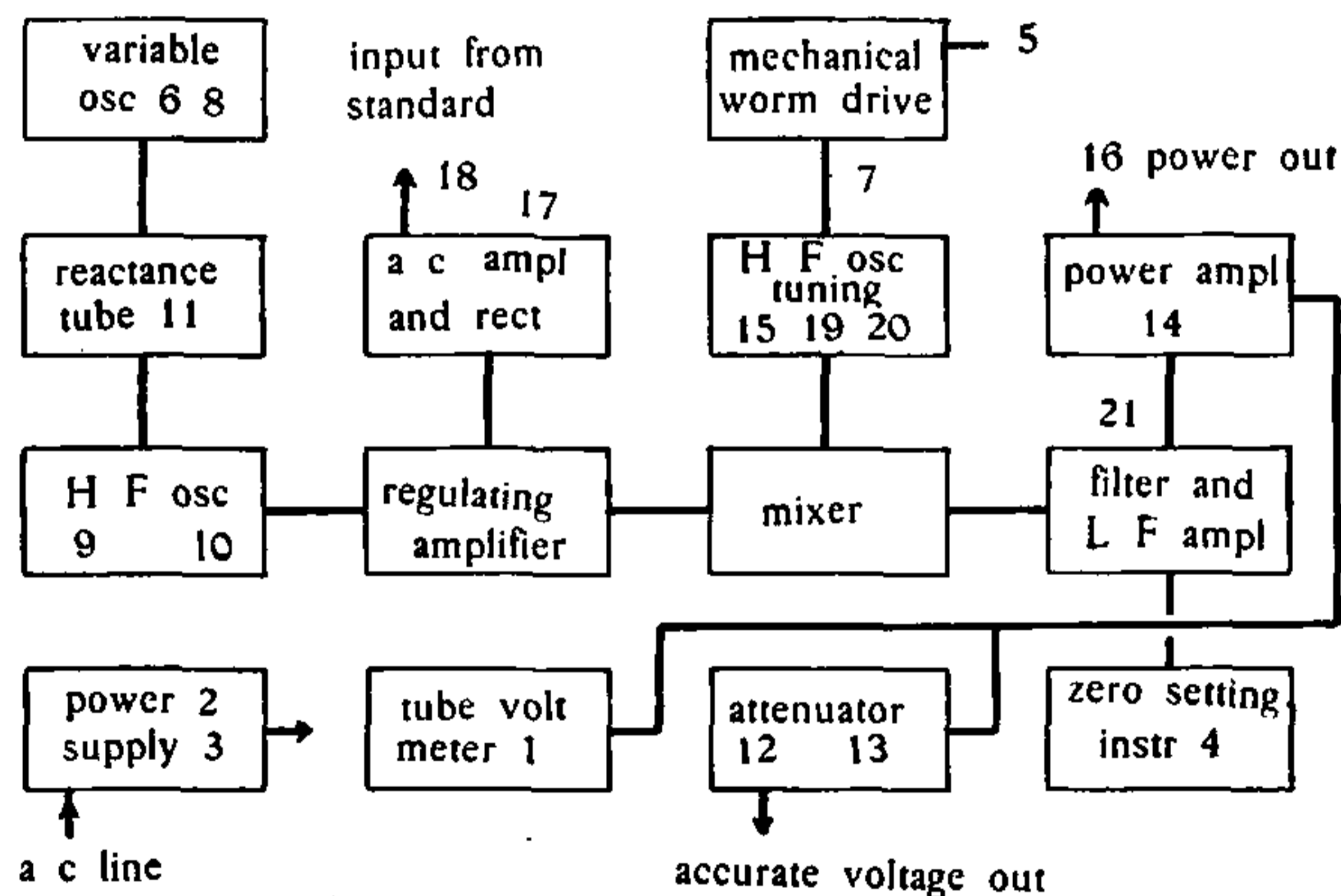

Fig. 6. Principle for the new beat-frequency oscillator designed for acoustical use.

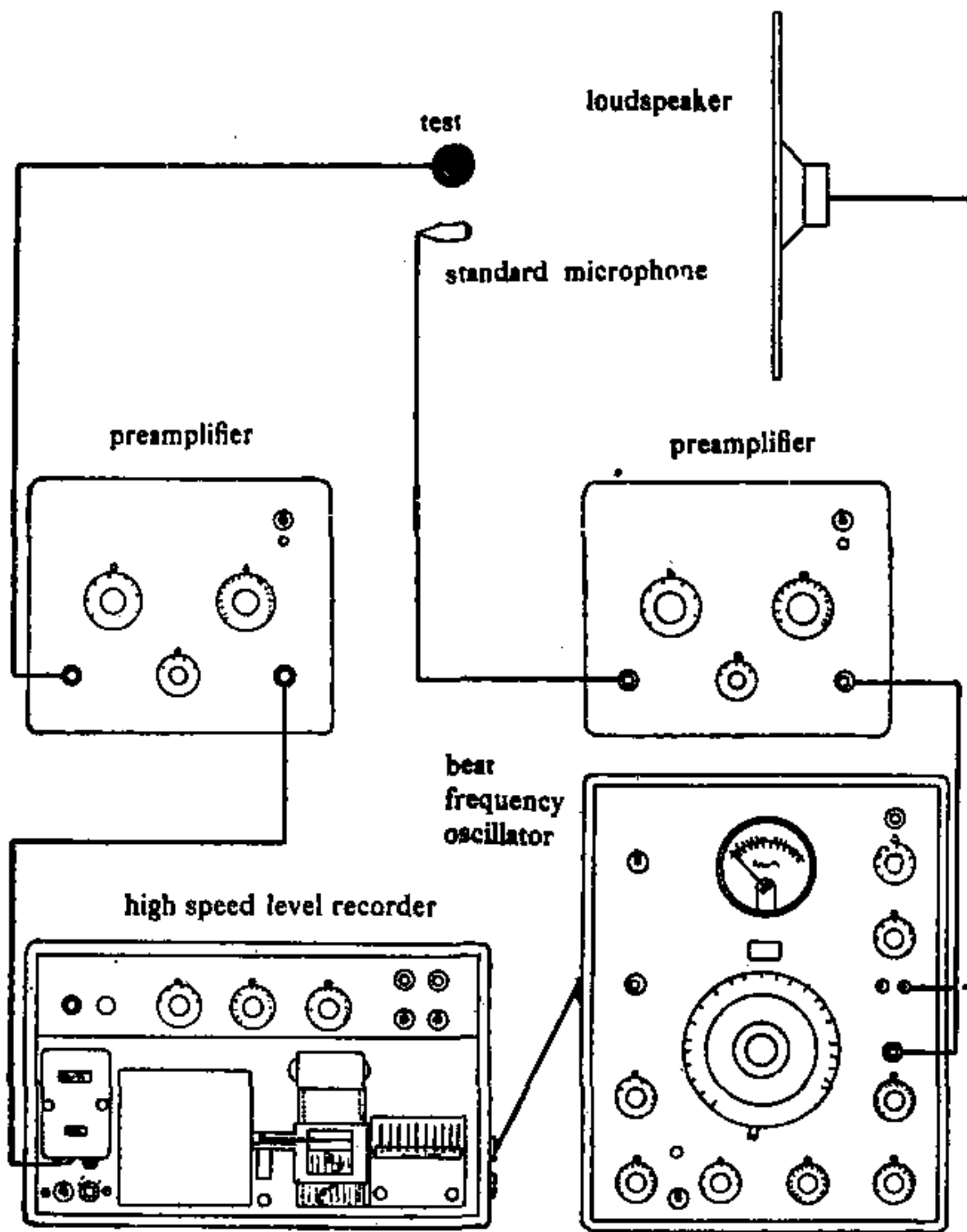

Fig. 7. Set-up for the automatic recording of frequency response curves of microphones.

per may be used, as the beat-frequency oscillator can be provided with a special contact wheel for giving impulses to a marking button and in this manner makes vertical lines in the diagram on beforehand determined frequencies.

Fig. 8 B shows such a recording on unprinted paper. The recorder itself indicates frequency marks, distinctly noticeable by the vertical lines.

In fig. 9 is shown the scheme for the automatic recording of insulation curves of test walls in an acoustic laboratory. The wall is inserted between the two measurement rooms, which acoustically are highly insulated from each other. The beat-frequency oscillator is connected with the two loudspeakers in the transmitter room, and the

power is regulated by the microphone in the receiver room, so that the sound pressure in the receiver room always will be adjusted to a constant

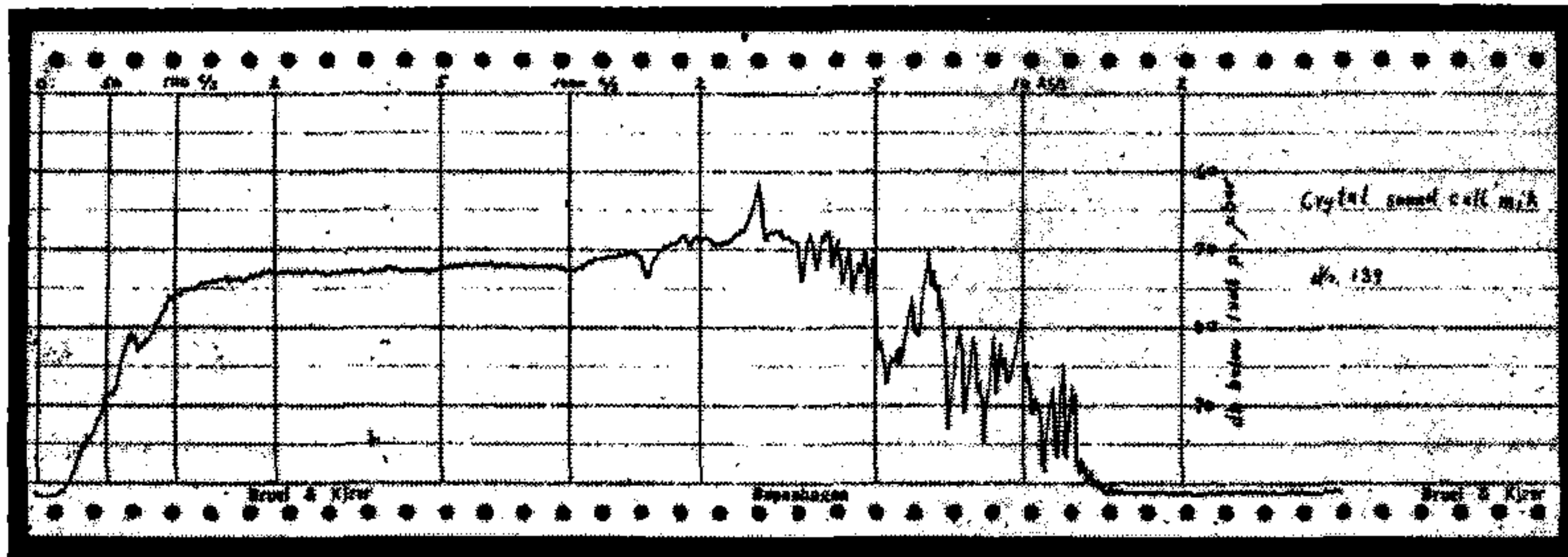

Fig. 8 A.

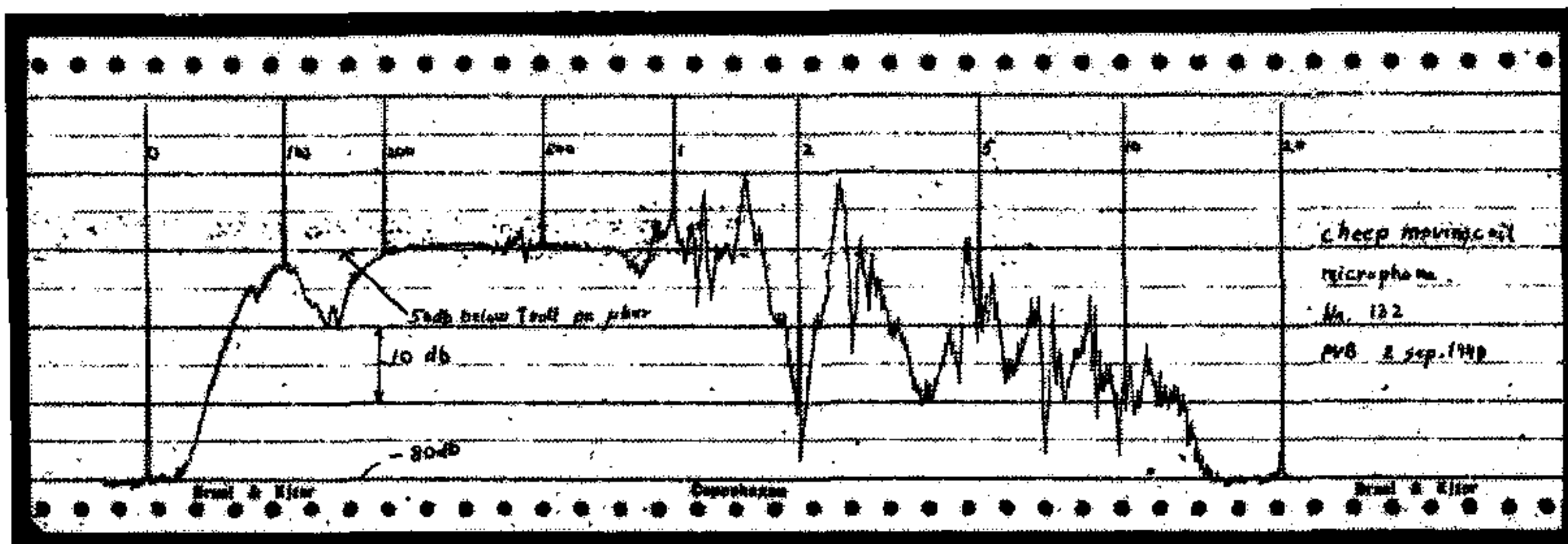

Fig. 8 B.

Fig. 8. Frequency response for a crystal microphone recorded respectively on paper with printed frequency coordinates and on paper without print, but with frequency marking from the beat-frequency oscillator.

level. By recording the sound level of the transmitter room the insulation curve of the wall will automatically be drawn as a function of the frequency. See fig. 10. The insulation figure I of the wall is expressed by

$$I = 20 \log \frac{p_1}{p_2} + 10 \log \frac{S}{A} \quad \text{db}$$

where p_1 and p_2 are the sound pressures in transmitter and receiver room, respectively, S the area of the wall, and A the total absorption of the receiver room*). When making automatic recordings of insulation curves, it is natural to adjust the total absorption in the receiver room so that it, independent on the frequency, always is equal to the area of the test wall, whereby the correction term is negligible. By means of carefully designed resonance absorbents it is fairly simple to get the right absorption in the most important frequency range from 30 to 8000 c/s. Instability in the system may sometimes be observed with the arrangement indicated in fig. 9, owing to the long distance between the loudspeakers and microphone 2. It will then be to the purpose to regulate the sound level in the transmission room, record the level from the receiver room, and at the same time reverse the curve in fig. 10.

Automatic recording of reverberation times can be made with the arrangement shown in the diagram fig. 11. The beat-frequency oscillator feeds the loudspeaker, and at constant intervals a switch on the recorder works a relay in the oscillator in order to cut off the loudspeaker current, by which means

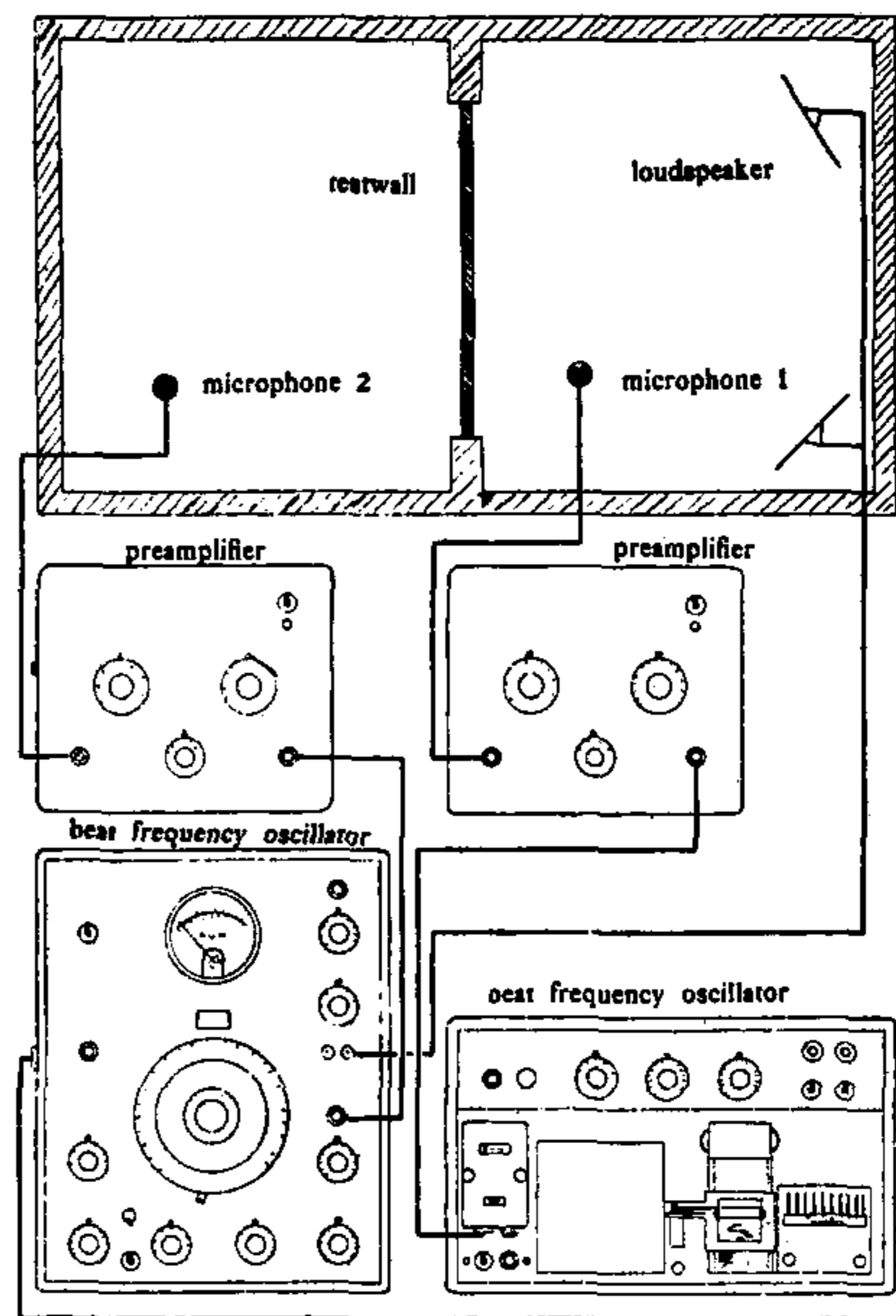

Fig. 9. Automatic measurements of sound insulation curves for test walls in an acoustic laboratory.

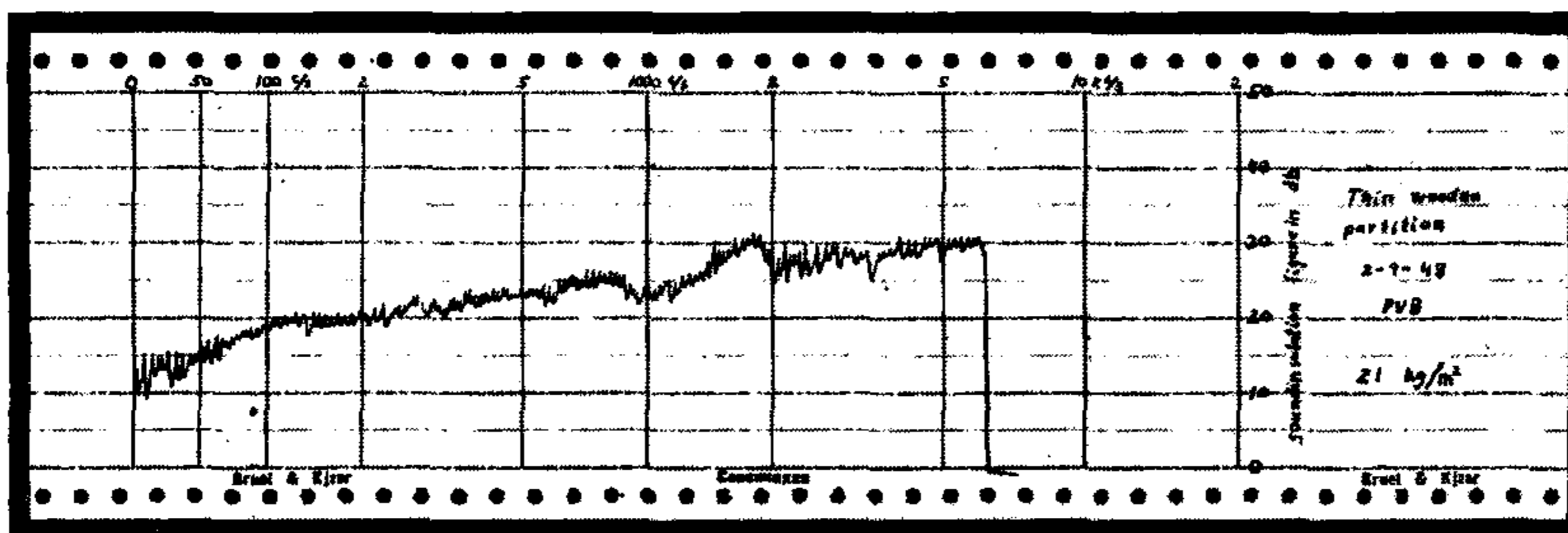

Fig. 10. Automatically recorded sound insulation curve of a thin wooden partition.

*) Brüel, Per V.: Akustiska Mätmetoder. (Acoustic measurement methods. In Swedish). Transactions of Chalmers University of Technology, Gothenburg, Sweden. No. 63, 1947.

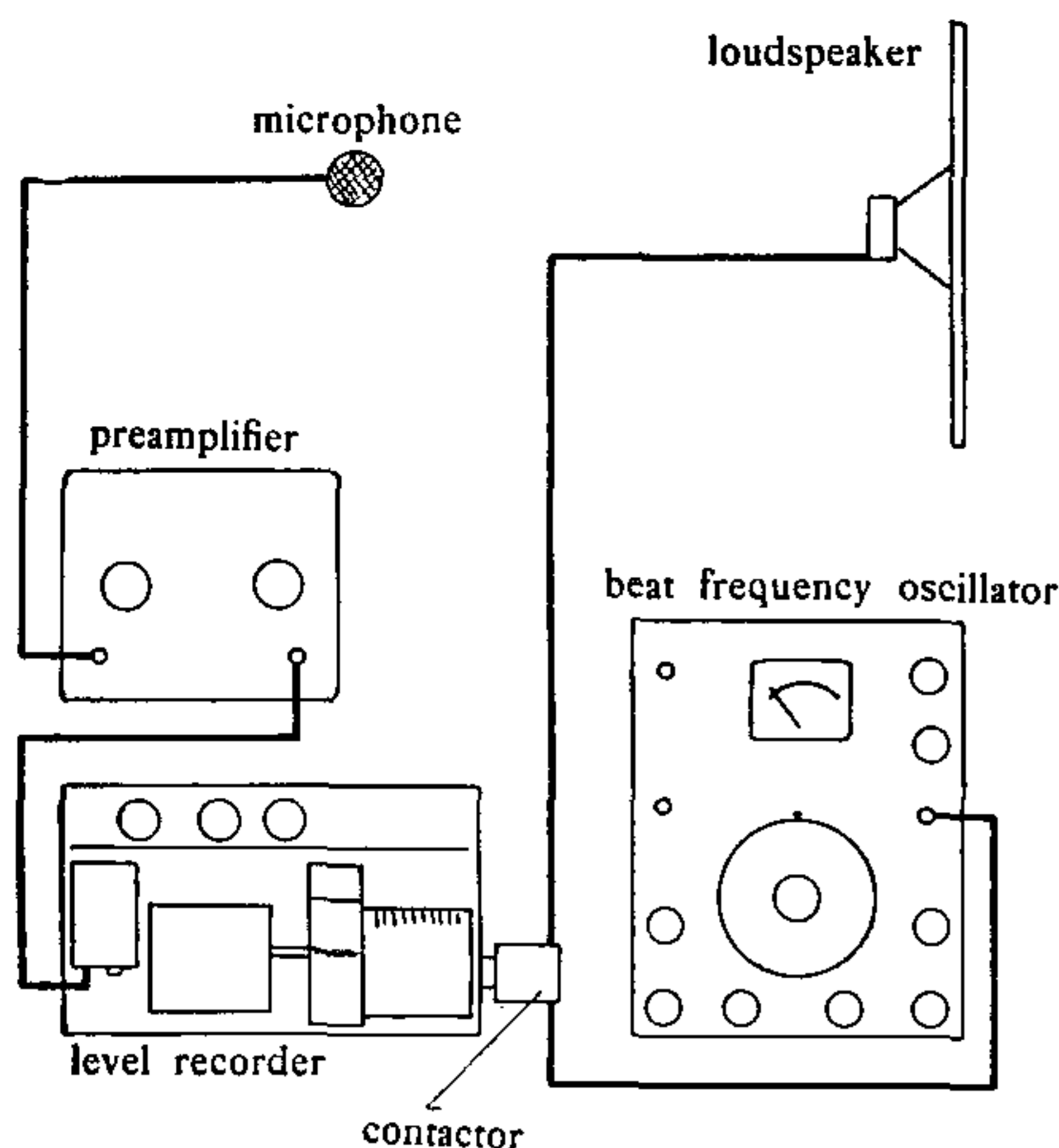

Fig. 11. Set-up for automatic recording of reverberation decay curves.

the recorder automatically will write a reverberation curve. Beforehand is known, at which frequencies the relay works, and thus also at which frequency the different reverberation curves are recorded. In this manner it is practicable to record a reverberation curve in 2-3 seconds, and the measurements can be made in close succession.

Owing to the obvious advantage of recording automatically and fast, the entire measurement arrangement has great practical importance when measuring in rooms with an audience. Of regard to the audience it is desirable that the measurements can be done in less than a minute. If all adjustments had to be made

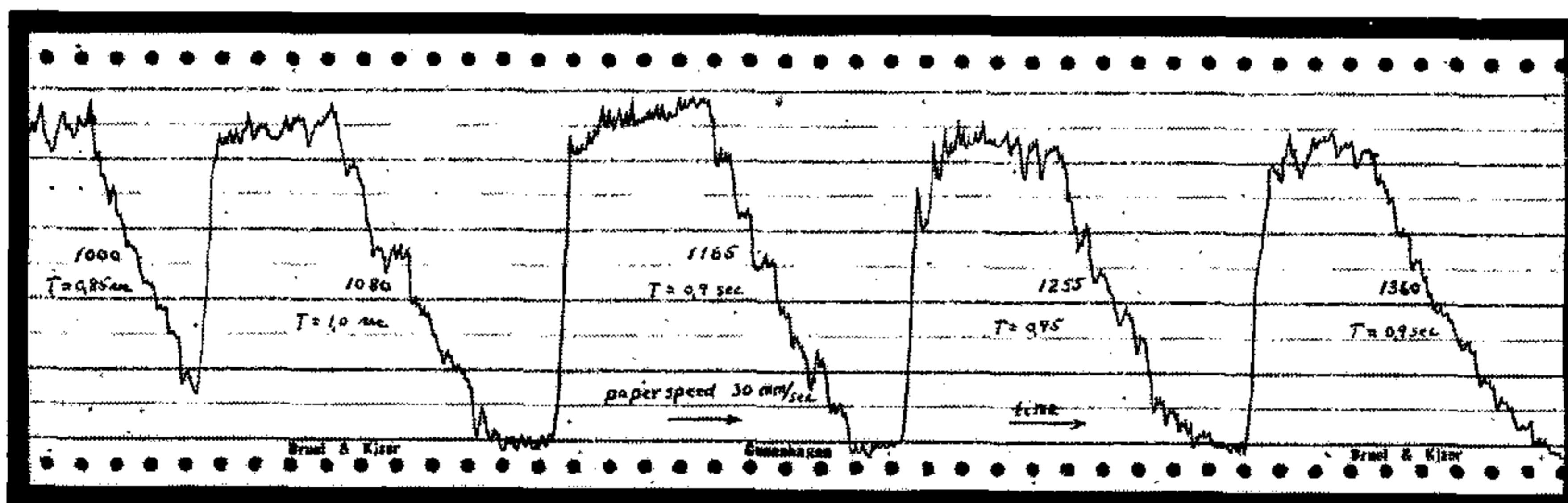

Fig. 12. Part of recording paper with automatic measurements of reverberation times. The different frequencies are written beside the curves.

by hand this should be impossible. The beat-frequency oscillator is adjusted to give ordinary warble tone, but of course the bandwidth and modulation frequency may be varied by hand during the measurements. An example of such a succession of curves is shown in fig. 12. Between each curve is an interval of 3 sec.

I should like to thank my assistants at the Acoustics Laboratory. Particularly Mr. F. Larris for his work on the mechanical problems of the recorder and Mr. U. Ingård for his assistance in the development of the electrical system of the model recorder.

To **A/S Brüel & Kjær**
NÆRUM, DENMARK

Name:

Profession:

Home Address:

.....

Business Address:

.....

Country:

wants regularly to receive Brüel & Kjær's Technical
Review.

Signature:

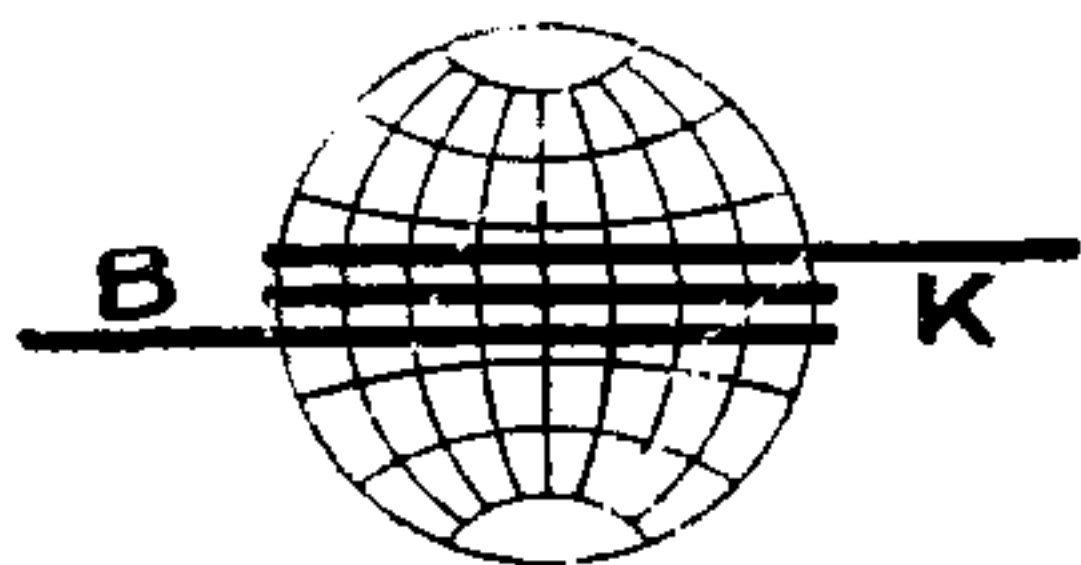

BRÜEL & KJÆR

Number 1
Jan. 1949

Technical Review

Teletechnical, acoustical and medical research

INTRODUCTION

We introduce the first issue of our Technical Review in the hope that a periodical of this sort will establish a close contact between our firm and the people and institutions who have been interested in our instruments through the years. The review will keep you constantly informed of the various applications of our instruments, and of the new developments and experiments in our laboratories. Furthermore we hope to be able to publish experts' experiences of new fields of applications of our products.

We intend to publish the Technical Review four or six times a year, but will not promise any fixed dates of issuing, as we only want to send it out when we have something of importance to discuss.

If you are interested in receiving the paper in the future, please, fill in the form on the back. You will then together with the next issue also receive a small cover in which to place the reviews.

Do you want more copies, or do you know somebody who might be interested in receiving our Technical Review, we should highly appreciate if you would let us know.

Aktieselskabet

Brüel & Kjær